

SNF472, A NOVEL INHIBITOR OF VASCULAR CALCIFICATION, COULD BE ADMINISTERED DURING HEMODIALYSIS TO ATTAIN POTENTIALLY THERAPEUTIC PHYTATE LEVELS



J. Perelló^{1,2}, M. Gómez³, M.D. Ferrer^{1,4}, N.Y. Rodríguez³, C. Salcedo¹, J.M. Buades⁵,
M.M. Pérez¹, E. Martín⁶, F. Maduell³



¹ Laboratoris Sanifit SL., Palma, Spain; ² Laboratori d'Investigació en Litiasi Renal, University of the Balearic Islands (UIB), Palma, Spain; ³ Hospital Clínic, Nephrology and Renal Transplantation, Barcelona, Spain; ⁴ D. Biologia Fonamental i Ciències de la Salut, UIB, Palma, Spain; ⁵ Hospital Son Llàtzer, Nephrology Service, Palma, Spain; ⁶ Kinrel, Madrid, Spain
Contact: joan.perello@sanifit.com

INTRODUCTION

Cardiovascular calcification (CVC) is a major concern in hemodialysis (HD) patients and the loss of endogenous modulators of calcification seems actively involved in the calcification process. Phytate is a crystallization inhibitor present in cells and tissues and its low molecular mass and high water solubility make it potentially dialyzable. SNF472 (the hexasodium salt of phytate), a selective calcification inhibitor, is being developed for the treatment of calciphylaxis and CVC in HD patients.

AIM

To evaluate SNF472's behavior during dialysis and the drug dialysability.

MATERIALS AND METHODS

Dialysability of SNF472 was assessed *in vitro* using online-hemodiafiltration (OL-HDF) and high-flux HD systems in blood and saline and in the presence and absence of calcium in the dialysis bath. Experiments using the bypass mode were also performed to check the interactions of SNF472 with the dialysis system. One liter of heparinized fresh blood (obtained from volunteer patients from the Haematology departments of Hospital Clínic and Hospital Son Llàtzer that were periodically undergoing therapeutic bleeding) was spiked with 8 mg/dl creatinine (as positive control) and introduced in a container maintained at 37 °C and one-hour dialysis session was simulated using MC 4008 and FMC 5008 dialysis devices. SNF472 (66.7, 30 and 10 mg/L) was infused for 20 minutes and samples were obtained at different time points for creatinine, total and ionized calcium and SNF472 levels quantification. An scheme of the experimental infusion system can be seen in Figure 1.

Figure 1. Scheme of the infusion system

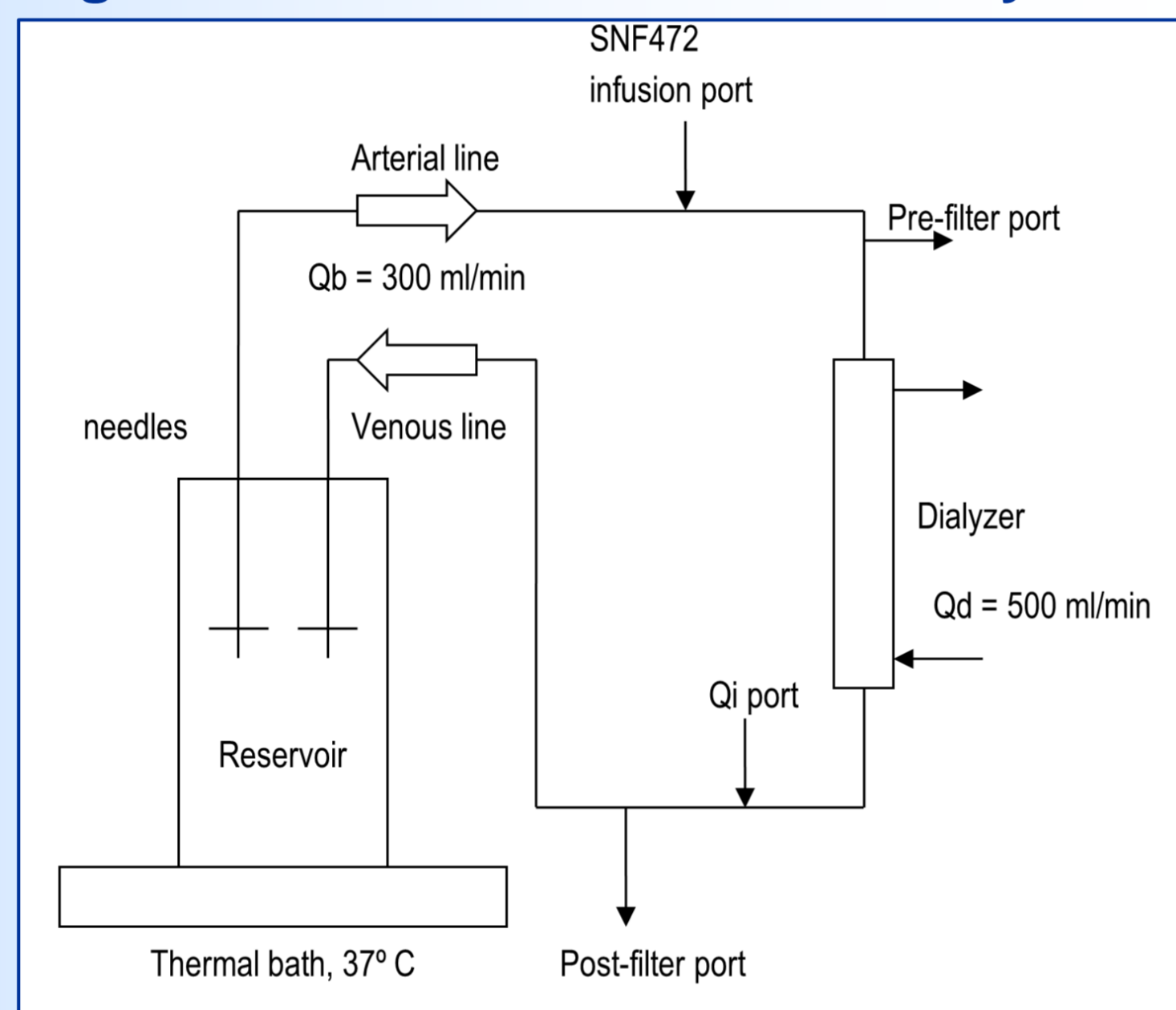

SNF472 was quantified by tandem mass spectrometry (the molecular ion of m/z 659 ($[M.-]$) was followed for quantitative purpose and was obtained after negative electrospray ionization) after gradient reversed-phase chromatography using TEAA 50mM pH 9 and ACN as mobile phase.

RESULTS

SNF472 increased in blood while infused, reached a plateau and remained nearly constant when added at concentrations of 30 and 66.67 mg/L. There was no apparent loss of SNF472 when the system ran in bypass mode. However, when SNF472 was added at 10 mg/L its levels in blood increased up to 8 mg/L during the infusion but then dropped with estimated values of K_{SNF472} of 36 ± 3 and 17 ± 4 mL/min for OL-HDF and HD, respectively (Figure 2, Table 1). Creatinine dialyzed with K_{cre} values of 204 ± 23 and 161 ± 17 mL/min for OL-HDF and HD, respectively (Table 1).

Figure 2. *In vitro* dialysability and stability of SNF472 under different experimental conditions

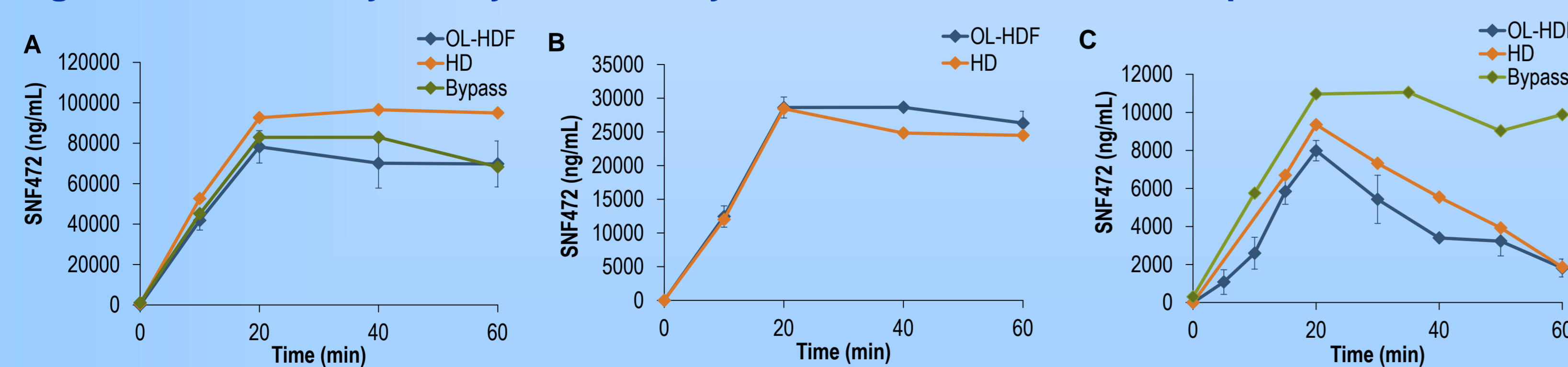

(A) 66.67 mg/L SNF472, (B) 30 mg/L SNF472, (C) 10 mg/L SNF472. SNF472 was infused at different concentrations for 20 minutes in 1L blood. OL-HDF experiments performed in triplicate, mean \pm SEM is represented HD and bypass experiments performed in single experiments. OL-HDF: Online-hemodiafiltration; HD: Hemodialysis; PMMA: Polymethylmethacrylate membrane.

In bypass conditions, calcium was slightly chelated during SNF472 infusion at 66.67 mg/L but when the system was switched to dialysis mode the calcium in the bath compensated this chelation.

Experiment	SNF472 clearance (ml/min)	Creatinine clearance (ml/min)
OL-HDF – Blood ¹	36 \pm 3	204 \pm 23
HD – Blood ¹	17 \pm 4	161 \pm 17
OL-HDF – Saline ³	7 \pm 2	321 \pm 35
HD – no calcium – Blood ²	115 \pm 6	171 \pm 25
HD – no calcium – Saline ³	80 \pm 13	238 \pm 7

Table 1. Clearance values for creatinine and SNF472 infused in blood and saline. ¹ 10 mg/L SNF472; ² 66.67 mg/L SNF472; ³ 30 mg/L SNF472. Clearance of SNF472 was calculated by the exponential fitting method for creatinine, using SNF472 pre-filter levels. Results represent fitted parameter mean values \pm asymptotic estimated error.

Figure 3. SNF472 effect on calcium levels in *in vitro* dialysis systems

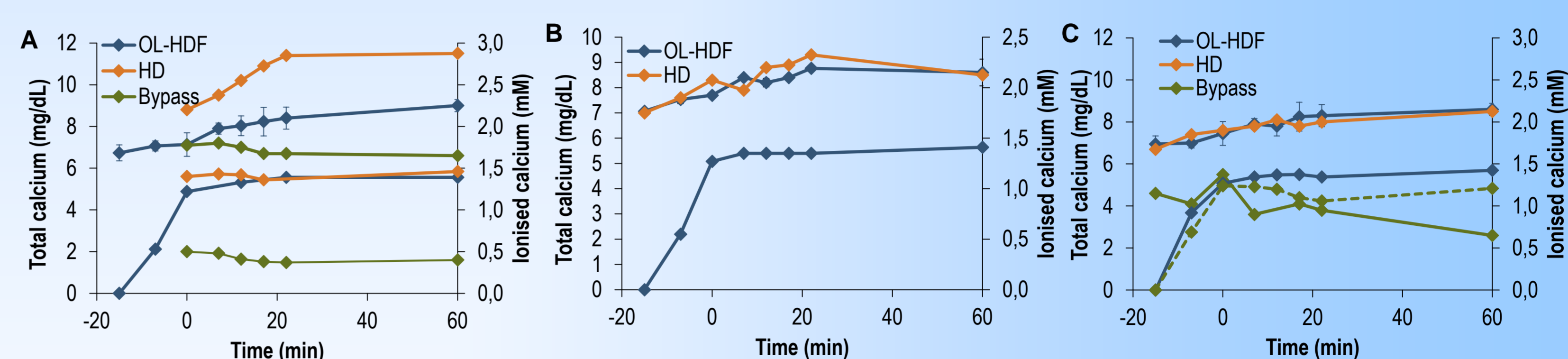

SNF472 was infused at different concentrations for 20 minutes in 1L blood. (A) 66.67 mg/L SNF472, (B) 30 mg/L SNF472, (C) 10 mg/L SNF472. Solid lines represent total calcium while dashed lines represent ionized calcium. OL-HDF experiments performed in triplicate, mean \pm SEM is represented. HD and bypass experiments performed in single experiments. OL-HDF: Online-hemodiafiltration; HD: Hemodialysis.

In order to check if the lack of dialysability observed at high concentrations was due to interactions with blood proteins the assays were performed in saline with 30 mg/L SNF472. SNF472 reached maximum plateau levels after infusion and these were maintained up until the end of the 60-minute period (Fig. 4A). Finally, the experiments were performed using a calcium-free dialysate in order to study the possible effect of SNF472-calcium aggregates formation. SNF472 levels rose in blood for the 20 minutes of infusion while total and ionized calcium levels dropped (Fig 4B and 4C). In the absence of calcium, SNF472 dialyzed in HD with a K_{SNF472} of 115 ± 6 mL/min for the 66.67 mg/L tested concentration and was undetectable after 50 minutes of study (Fig. 4B).

Figure 4. SNF472 dialysability in saline and blood in absence of calcium in the dialysis bath

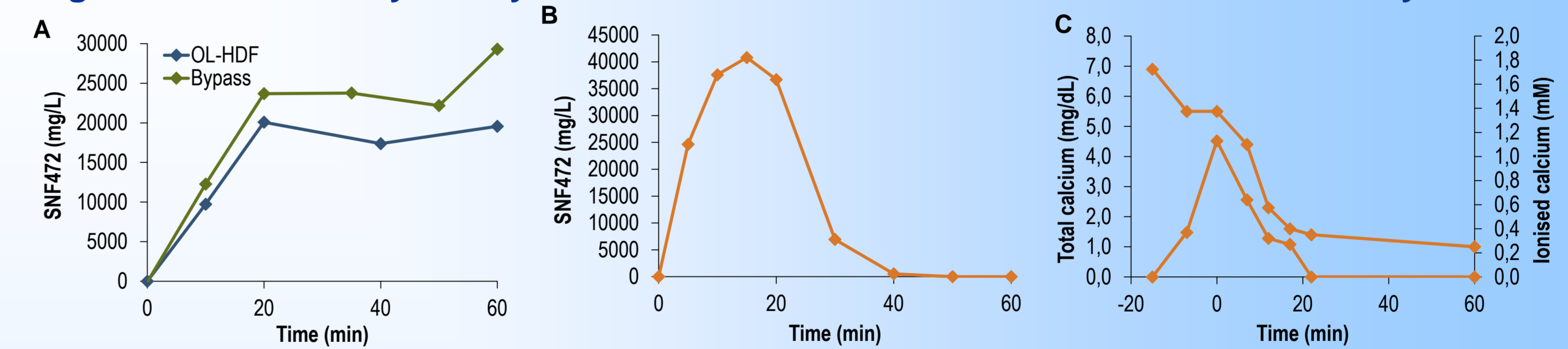

(A) SNF472 was infused at 30 mg/L for 20 minutes in 1L saline; (B, C) SNF472 was infused for 20 minutes at 66.67 mg/L in 1L blood and the experiment was performed with hemodialysis; (B) SNF472 levels in blood; (C) Total (solid lines) and ionized (dashed lines) calcium levels. OL-HDF: Online-hemodiafiltration.

CONCLUSIONS

- Phytate shows a low dialysability (clearance in the range 17-36 ml/min and approximately 10% of creatinine clearance), which is only observed at low phytate concentrations. This low dialysability may be attributed to the formation of colloidal complexes with calcium.
- The administration of SNF472 as an exogenous source of phytate during dialysis allows to attain the supra-physiological levels required for its potential therapeutic anti-calcification properties. As SNF472 is infused during the whole dialysis session the low clearance will not affect the drug's systemic exposure required for its activity.
- SNF472 is a calcification inhibitor by direct blockade of HAP crystallization. However, calcium chelating activity is seen at high SNF472 doses. This chelating effect is compensated by the calcium in the dialysis bath, so no hypocalcemia is expected in HD patients.

This study was supported by FEDER funds ISCIII RETIC REDINREN RD012/20021 and RETOS COLABORACIÓN: RTC-2014-2460-1 ISCIII grant (Ministerio de Economía y Competitividad. Government of Spain)



Cofinanciado por el Fondo Europeo de Desarrollo Regional (FEDER). Unión Europea. Una manera de hacer Europa